

# QTS<sup>®</sup> Series Model QTS-3 Vac

Parts Manual  
Record of Change 100

This manual contains important safety information and must be made available to all personnel who operate and/or maintain this product. Carefully read this manual before attempting to operate or perform maintenance on this compressor.

*Fill Out & Return Warranty Registration Card Located Inside*

Manual No. 50347-100

February 2010 Edition



# TABLE OF CONTENTS

Serial number Identification ..... 1  
 Ordering Replacement Parts ..... 1  
 Crankcase Lubricant Capacity ..... 1  
 Quin-Cip® Lubricant ..... 1  
 Crankcase Group ..... 2  
 Crankshaft Group ..... 3  
 Cylinder Group ..... 4  
 Piston Group ..... 5  
 Recommended Spare Parts ..... 6

## SERIAL NUMBER IDENTIFICATION

The unit serial number identification tag is located on the air tank top plate. The basic compressor serial number decal is located on the basic compressor, opposite the flywheel side. *Fill in the numbers from your compressor unit and basic compressor in the corresponding spaces provided here, and reference this page when ordering replacement parts.*

Unit Serial Number
Basic Serial Number

All replacement parts are to be ordered through an authorized Quincy distributor. Insist on genuine Quincy Compressor parts only! Failure to do so may void warranty.

## ORDERING REPLACEMENT PARTS

Prompt service can be rendered on repair parts orders if the following information is given:

- Item 1)** the model number, record of change number, & serial number.
- Item 2)** the exact part number needed. (Do not order by item numbers.)
- Item 3)** the exact quantity needed.
- Item 4)** the preferred type of transportation.

# CHANGES

*Since last printing dated February 2004:*

The head and cylinder fasteners and head gasket were redesigned.

## QUIN-CIP® LUBRICANT

Refer to the chart below to order QUIN-CIP compressor lubricant from your local authorized Quincy distributor.

Package	Part No.	Description
Quart	112541Q032	1 qt., SAE 10W
Quart Case	112541C032	(12)-1 qt., SAE 10W
Quart	112542Q068	1 qt., SAE 20
Quart Case	112542C068	(12)-1 qt., SAE 20
Quart	112543Q100	1 qt., SAE 30
Quart Case	112543C100	(12)-1 qt., SAE 30

## CRANKCASE LUBRICANT CAPACITY

Model	Capacity
QTS-3 VAC	12 oz. (354 ml.)

## RECOMMENDED RPM OPERATING RANGE

600-1100 RPM

**CAUTION !**

Refer to the QTS Industrial / Air Master Series instruction manual for vital lubrication information.

**CAUTION !**

Follow all safety precautions outlined in the QTS Industrial / Air Master Series instruction manual.

**WARNING !**

Do not operate this compressor without a totally enclosed belt guard or any other required safety equipment.

**DANGER !**

Air used for breathing or food processing must meet OSHA 1910.134 or FDA 21 CFR 178.3570 regulations. Failure to do so may cause severe injury or death.

# CRANKCASE GROUP 112608-009

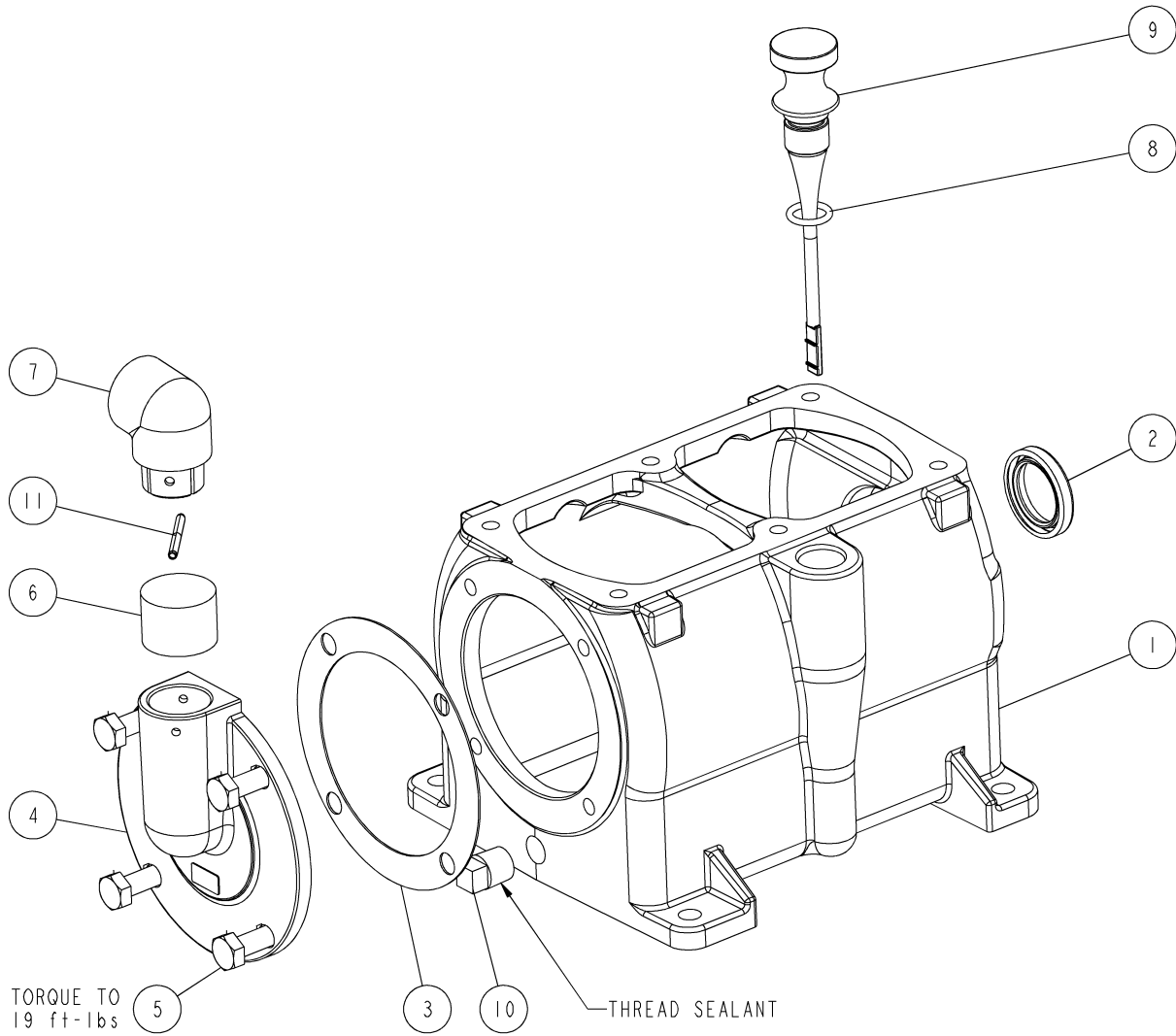

ITEM	PART NUMBER	QTY	DESCRIPTION
1	112581	1	CRANKCASE
2	112596-001	1	OIL, SEAL
3	112592	1	GASKET
4	112585	1	BEARING CARRIER
5	115037-K10	4	SCREW, CAP HEX, SEALANT, GRADE 5
6	110095-002	1	FILTER
7	111349-001	1	BREATHER ELBOW
8	123157-112	1	O-RING
9	110070-7	1	DIPSTICK
10	2574	1	PIPE PLUG, 1/4 NPT
11	115808-F14	1	SPRING PIN

# CRANKSHAFT GROUP 112609

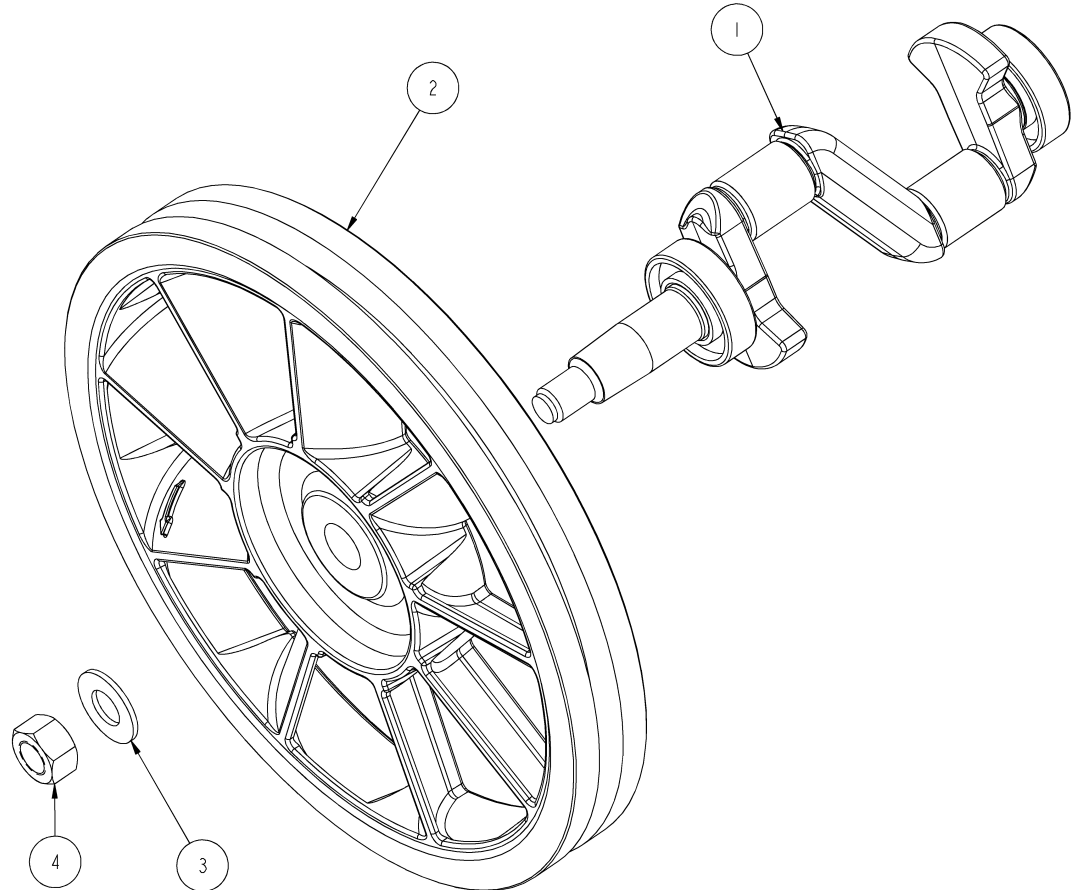

TORQUE TO 50 ft-lbs  
LEFT HAND THREAD

CRANKSHAFT GROUP 112609 BILL OF MATERIALS			
ITEM	PART NUMBER	QTY	DESCRIPTION
1	112584X	1	CRANKSHAFT ASSY (INCLUDES BEARINGS)
2	114211	1	SHEAVE, 11.8PD, CCW, 1 GRV, A-SECTION BELT
3	110428N062	1	FLAT WASHER
4	112607	1	HEX. NUT

# CYLINDER GROUP 115738

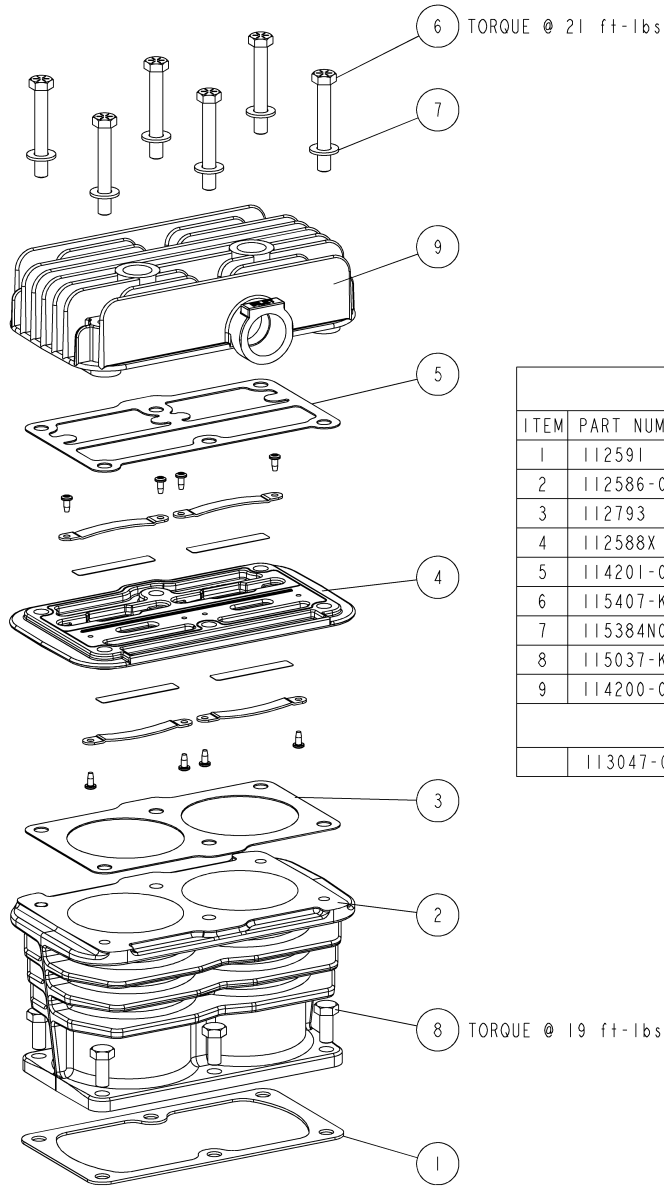

115738 BILL OF MATERIALS			
ITEM	PART NUMBER	QTY	DESCRIPTION
1	112591	1	GASKET
2	112586-003	1	CYLINDER, AIRCOOLED (2.75 DIA)
3	112793	1	GASKET, CYL/VALVE PLATE
4	112588X	1	VALVE PLATE ASSEMBLY
5	114201-001	1	HEAD GASKET
6	115407-K18	6	HEX, SCREW GRADE 8
7	115384N031	6	WASHER
8	115037-K10	6	SCREW, CAP HEX, SEALANT, GRADE 5
9	114200-002	1	HEAD
MAINTENANCE PARTS			
	113047-001	1	VALVE REPAIR KIT (INCLUDES ITEM 3,4,5)

# PISTON GROUP 115737

Pip marks are located on top surface of the rings

**IMPORTANT:** Rings must be assembled in the position shown and in the following sequence:

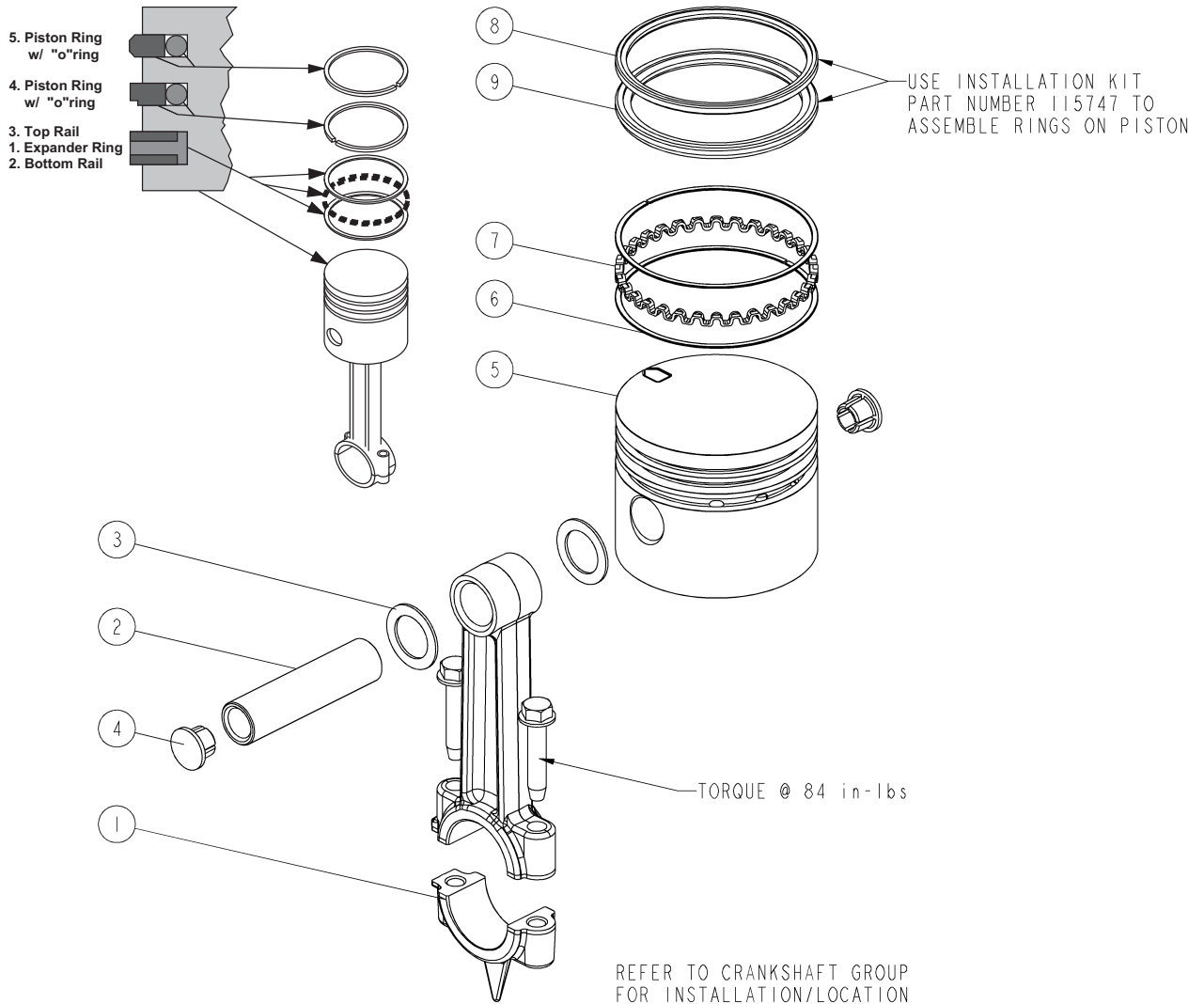

## 115737 BILL OF MATERIALS

ITEM	PART NUMBER	QTY	DESCRIPTION
1	112583	1	AY, CON/ROD
2	110190-025	1	PISTON PIN
3	112597	2	NYLON WASHER
4	111105-002	2	PISTON PIN PLUG
5	112582-001	1	PISTON
6	112650	2	OIL RING RAIL
7	112651	1	OIL RING SPACER
8	115734	1	PISTON RING
9	115735	1	PISTON RING
MAINTENANCE PARTS			
	113046V	1	REPLACEMENT RING SET (INCLUDES ITEMS 6,7,8,9)
	112583K	1	REPLACEMENT CON/ROD (ITEM 1)
	115756K	1	REPLACEMENT PISTON / RING ASSEMBLY (INCLUDES ITEMS 5,6,7,8,9-RINGS ASSEMBLED ON PISTON)

<b>Recommended Spare Parts</b>		
<b>Qty.</b>	<b>Part Number</b>	<b>Description</b>
1	113047-001	valve repair kit
1	113048-001	gasket set

<b>Gasket Set 113048-001</b>		
<b>Qty.</b>	<b>Description</b>	
1	112596-001	shaft seal
1	112592	bearing carrier gasket
1	123157-112	"o"ring, 3/32 wide x .69 OD
1	112591	gasket, cylinder to crankcase
1	112793	gasket, cylinder to valve plate
1	114201-001	head gasket

<b>Valve Repair Kit 113047-001</b>		
<b>Qty.</b>	<b>Description</b>	
1	112793	gasket, cylinder to valve plate
1	112588X	valve plate assembly
1	114201-001	head gasket

<b>Replacement Ring Set 113046V</b>		
<b>Qty.</b>	<b>Description</b>	
2	112650	oil ring rail
1	112651	oil ring expander
1	115734	piston ring
1	115735	piston ring



# QUINCY COMPRESSOR

## STANDARD TERMS AND CONDITIONS

**LEGAL EFFECT:** Except as expressly otherwise agreed to in writing by an authorized representative of Seller, the following terms and conditions shall apply to and form a part of this order and any additional and/or different terms of Buyer's purchase order or other form of acceptance are rejected in advance and shall not become a part of this order.

The rights of Buyer hereunder shall be neither assignable nor transferable except with the written consent of Seller.

This order may not be canceled or altered except with the written consent of Seller and upon terms which will indemnify Seller against all loss occasioned thereby. All additional costs incurred by Seller due to changes in design or specifications, modification of this order or revision of product must be paid for by Buyer.

In addition to the rights and remedies conferred upon Seller by this order, Seller shall have all rights and remedies conferred at law and in equity and shall not be required to proceed with the performance of this order if Buyer is in default in the performance of such order or of any other contract or order with seller.

**TERMS OF PAYMENT:** Unless otherwise specified in the order acknowledgment, the terms of payment shall be 1% 15, net forty-five (45) days after shipment. These terms shall apply to partial as well as complete shipments. If any proceeding be initiated by or against Buyer under any bankruptcy or insolvency law, or in the judgment of Seller the financial condition of Buyer, at the time the equipment is ready for shipment, does not justify the terms of payment specified, Seller reserves the right to require full payment in cash prior to making shipment. If such payment is not received within fifteen (15) days after notification of readiness for shipment, Seller may cancel the order as to any unshipped item and require payment of its reasonable cancellation charges.

If Buyer delays shipment, payments based on date of shipment shall become due as of the date when ready for shipment. If Buyer delays completion of manufacture, Seller may elect to require payment according to percentage of completion. Equipment held for Buyer shall be at Buyer's risk and storage charges may be applied at the discretion of Seller.

Accounts past due shall bear interest at the highest rate lawful to contract for but if there is no limit set by law, such interest shall be eighteen percent (18%). Buyer shall pay all cost and expenses, including reasonable attorney's fees, incurred in collecting the same, and no claim, except claims within Seller's warranty of material or workmanship, as stated below, will be recognized unless delivered in writing to Seller within thirty (30) days after date of shipment.

**TAXES:** All prices exclude present and future sales, use, occupation, license, excise, and other taxes in respect of manufacture, sales or delivery, all of which shall be paid by Buyer unless included in the purchase price at the proper rate or a proper exemption certificate is furnished.

**ACCEPTANCE:** All offers to purchase, quotations and contracts of sales are subject to final acceptance by an authorized representative at Seller's plant.

**DELIVERY:** Except as otherwise specified in this quotation, delivery will be F. O. B. point of shipment. In the absence of exact shipping instruction, Seller will use its discretion regarding best means of insured shipment. No liability will be accepted by Seller for so doing. All transportation charges are at Buyer's expense. Time of delivery is an estimate only and is based upon the receipt of all information and necessary approvals. The shipping schedule shall not be construed to limit seller in making commitments for materials or in fabricating articles under this order in accordance with Seller's normal and reasonable production schedules.

Seller shall in no event be liable for delays caused by fires, acts of God, strikes, labor difficulties, acts of governmental or military authorities, delays in transportation or procuring materials, or causes of any kind beyond Seller's control. No provision for liquidated damages for any cause shall apply under this order. Buyer shall accept delivery within thirty (30) days after receipt of notification of readiness for shipment. Claims for shortages will be deemed to have been waived if not made in writing with ten (10) days after the receipt of the material in respect of which any such shortage is claimed. Seller is not

responsible for loss or damage in transit after having received "In Good Order" receipt from the carrier. All claims for loss or damage in transit should be made to the carrier.

**TITLE & LIEN RIGHTS:** The equipment shall remain personal property, regardless of how affixed to any realty or structure. Until the price (including any notes given therefore) of the equipment has been fully paid in cash, Seller shall, in the event of Buyer's default, have the right to repossess such equipment.

**PATENT INFRINGEMENT:** If properly notified and given an opportunity to do so with friendly assistance, Seller will defend Buyer and the ultimate user of the equipment from any actual or alleged infringement of any published United States patent by the equipment or any part thereof furnished pursuant hereto (other than parts of special design, construction, or manufacture specified by and originating with Buyer), and will pay all damages and costs awarded by competent court in any suit thus defended or of which it may have had notice and opportunity to defend as aforesaid.

**STANDARD WARRANTY:** Seller warrants that products of its own manufacture will be free from defects in workmanship and materials under normal use and service for the period specified in the product instruction manual. Warranty for service parts will be Ninety (90) days from date of factory shipment. Electric Motors, gasoline and diesel engines, electrical apparatus and all other accessories, components and parts not manufactured by Seller are warranted only to the extent of the original manufacturer's warranty.

Notice of the alleged defect must be given to the Seller, in writing with all identifying details including serial number, type of equipment and date of purchase within thirty (30) days of the discovery of the same during the warranty period.

Seller's sole obligation on this warranty shall be, at its option, to repair or replace or refund the purchase price of any product or part thereof which proves to be defective. If requested by Seller, such product or part thereof must be promptly returned to seller, freight prepaid, for inspection.

Seller warrants repaired or replaced parts of its own manufacture against defects in materials and workmanship under normal use and service for ninety (90) days or for the remainder of the warranty on the product being repaired.

This warranty shall not apply and Seller shall not be responsible or liable for:

- (a) Consequential, collateral or special losses or damages;
- (b) Equipment conditions caused by fair wear and tear, abnormal conditions of use, accident, neglect or misuse of equipment, improper storage or damage resulting during shipping;
- (c) Deviation from operating instructions, specifications or other special terms of sale;
- (d) Labor charges, loss or damage resulting from improper operation, maintenance or repairs made by person(s) other than Seller or Seller's authorized service station.

In no event shall Seller be liable for any claims whether arising from breach of contract or warranty or claims of negligence or negligent manufacture in excess of the purchase price.

**THIS WARRANTY IS THE SOLE WARRANTY OF SELLERS AND ANY OTHER WARRANTIES, WHETHER EXPRESS OR IMPLIED IN LAW OR IMPLIED IN FACT, INCLUDING ANY WARRANTIES OF MERCHANTABILITY AND FITNESS FOR PARTICULAR USE ARE HEREBY SPECIFICALLY EXCLUDED.**

**LIABILITY LIMITATIONS:** Under no circumstances shall the Seller have any liability for liquidated damages or for collateral, consequential or special damages or for loss of profits, or for actual losses or for loss of production or progress of construction, whether resulting from delays in delivery or performance, breach of warranty, negligent manufacture or otherwise.

**ENVIRONMENTAL AND OSHA REQUIREMENTS:** At the time of shipment of the equipment from the factory, Quincy Compressor / Ortman Fluid Power will comply with the various Federal, State and local laws and regulations concerning occupational health and safety and pollution. However, in the installation and operation of the equipment and other matters over which the seller has no control, the Seller assumes no responsibility for compliance with those laws and regulations, whether by the way of indemnity, warranty or otherwise.

June 30, 2003

Quincy Compressor



**Reciprocating / Systems:** 217.222.7700  
**E-mail:** info@quincycompressor.com  
**Website:** quincycompressor.com

